

INSTRUCTION MANUAL



**WATER-DISTRIBUTOR
JUNGBRUNNEN 25-00
WITH REVERSE OSMOSIS SYSTEM**

Thank you for choosing our Water Distributor based on **NEW LINE Molecular Reverse Osmosis System**. It is a perfect source of cristal clear cold, warm and hot water to be installed at home or office. You have now become the owner of the highest quality Water Distributor, which will provide you with cristal clear water without the necessity to use water bottles. Additionally, New Line Molecular Reverse Osmosis System assures perfect water treatment based on the innovative technology and German licence. New Line system reduces the majority of impurities present in water, such as rust, silt, chemical compounds, bacteria, viruses and many others.

Water Distributor uses water pressure provided by the water mains. Raw water flows through prefilters and reverse osmosis membrane, which remove all impurities. Then, purified water is saturated with minerals received from carefully selected natural dolomite stones. Next, water goes to water tanks, where it is stored, and dirty water is directed to the drain.

Please read carefully the Instruction Manual and follow all guides while installing.

IMPORTANT SYMBOLS!



Denotes issues you should pay special attention to.



Denotes absolute necessity to follow the instructions given due to safety issues or possible severe system damage.



Reference to other chapters of the Instructions Manual where a given issue is described in more detail.



Chapters destined particularly for professional servicemen.

TABLE OF CONTENTS

	Page
1. BEFORE YOU INSTALL THE WATER DISTRIBUTOR	4
2. SAFETY ISSUES	4
3. BASIC WATER DISTRIBUTOR CW-929 ELEMENTS	5
4. OPERATING FUNCTIONS OF WATER DISTRIBUTOR EQUIPPED WITH AN RO SYSTEM	6
4.1 Water filtration	6
4.2 Tank filling	7
4.3 Water cooling system	7
4.4 Flow restrictor	7
5. WATER DISTRIBUTOR BASIC TECHNICAL PARAMETERS	8
6. INSTALLATION SCHEMES	9
6.1 Water installation scheme	9
6.2 Electrical installation scheme	10
7. USEFUL INSTALLATION TIPS	11
7.1 Standard quick connection application (QC-type connections)	11
7.2 Disconnection of quick connection application (QC-type connections)	11
8. WATER DISTRIBUTOR INSTALLATION TO WATER MAINS	11
8.1 Installation to cold water inlet	11
8.1.1 METHOD 1: 3/4" brass water feeder – instalaltion at faucet	11
8.1.2 METHOD 2: 3/8" or 1/2" water feeder - installation at water inlet	12
8.2 Installation of drain saddle	12
8.3 Pressure control and system rinsing	13
9. WATER DISTRIBUTOR OPERATION CONDITIONS	14
9.1 Precuations	14
9.2 How to get water of requested temperature.	15
10. WATER DISTRIBUTOR SERVICE AND MAINTENANCE	16
10.1 Water Distributor cleaning	16
10.2 Prefilters exchange	16
10.3 Membrane exchange	17
10.4 Postfilters exchange	17
11. TROUBLESHOOTING	18
	18

1. BEFORE YOU INSTALL WATER DISTRIBUTOR CW-929



CAUTION!: Do not push the “HOT POWER” button until the main water tank is filled with water.



CHECK RAW WATER INLET: COLD raw water must fulfill certain conditions. Please refer to the specification outlined on p.8. If raw water does not fulfill the required technical parameters, then the Molecular Reverse Osmosis system will not work properly and cartridges and membrane lifetime may be substantially reduced.



CAUTION!: Chlorine dissolved in water may severely damage the membrane. Prefilters remove chlorine only to the level given on p.8. It is essential that one carries out periodical prefilter exchange and service of the whole filtration system. Please refer to WATER DISTRIBUTOR SERVICE AND MAINTENANCE described on p.16-17.



CAUTION!: Rinse the membrane and postfilters before the first use. Membrane is protected by a food preservative, which must be washed out before the first water consumption from the Water Distributor. For details please refer to p.13.

2. SAFETY



Read carefully all Water Distributor installation and maintenance guides. Follow the instructions attentively in order to avoid mistakes that may lead to severe system damage.



DO NOT use Water Distributor to purify water coming from an unknown source, contaminated, microbiologically unsafe, or not fulfilling necessary technical parameters listed on p.8.



Check the local sanitary regulations and other concerning water system installations. Follow the local sanitary regulations as they may differ from those given in the above Instruction Manual.



The operating pressure for Water Distributor with an RO system is between 2,2 bar (32 psi) (minimum) and 6,0 bar (87 psi) (maximum). If the pressure exceeds 6 bar a pressure reduction valve must be installed.



DO NOT install Water Distributor CW-929 outdoors or in extreme temperatures. Raw water temperature must be within the range from 4° C to 45° C.



DO NOT connect Water Distributor CW-929 to hot water inlet!



Reverse osmosis membrane is protected with a food preservative for storage and transportation period. Make sure the membrane is rinsed properly according to the instructions given on p.13.



- 1. Water level indicator
- 2. Control panel
- 3. Hot water tap
- 4. Cool water tap
- 5. Cold water tap
- 6. Cup stand
- 7. Top cover
- 8. Cold water tank

- 9. Cooling system condenser
- 10. Water drainage for tanks
- 12. Refrigerator compressor
- 13. Waste water connection
- 14. Water connection
- 15. Power supply

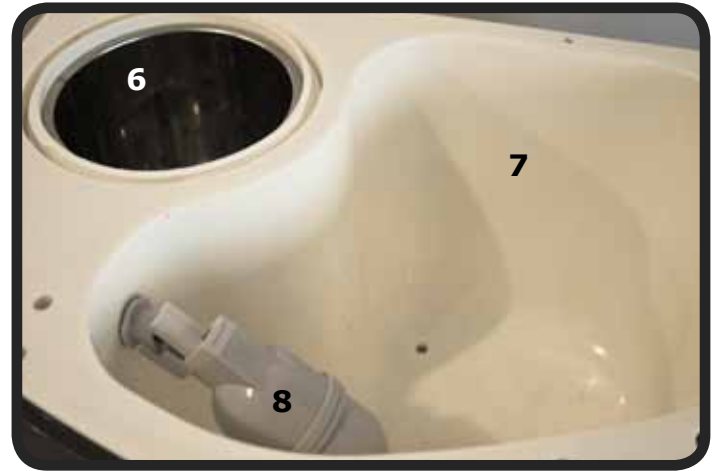

1. Top cover
2. Outer plate of warm water tank
4. Steam outlet opening
5. Steam outlet cover
6. Hot water tank
7. Cool water tank
8. Hydraulic floating valve

4. OPERATING FUNCTIONS OF WATER DISTRIBUTOR EQUIPPED WITH AN RO SYSTEM

4.1 WATER FILTRATION



SEDIMENT PREFILTER– first level of filtration

Raw water flows through sediment prefilter, which removes mechanical impurities such as sand, silt, rust etc.

SEDIMENT-CARBON prefilter – second level of filtration

Sediment-carbon prefilter is made of polypropylene fibre and granular activated carbon. Removes mechanical impurities, which were not removed by the first prefilter and improves water taste and smell. Additionally, removes chlorine, its poisonous derivatives and chemical compounds.

MEMBRANE – third level of filtration

Membrane is a sort of barrier for organic and non-organic impurities, solid bodies dissolved in water, heavy metals, radioactive elements and carcinogenic substances. Membrane lets pass only water particles, as their pores have the size of 0,0001 mm. Filtered water is stored in water tank and dirty water is directed by the flow restrictor to the drain.

GRANULAR ACTIVATED CARBON POSTFILTER – fourth level of filtration

Filtered water goes through the granular activated carbon postfilter, which improves water taste and smell.

Optional:

MINERALISING POSTFILTER – fifth level of filtration

After the fourth level of filtration water goes through the mineralising postfilter, which saturates water with mineral salt ions. These postfilters contain natural minerals, the structure of which favours their proper solution in water.

4.2 TANK FILLING

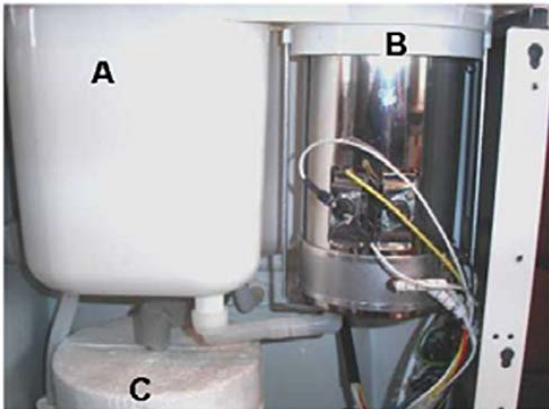

There are three tanks in Water Distributor CW-929:

A. Cool water tank ~ 8 l capacity

B. Hot water tank ~2 l capacity

C. Cold water tank ~ 4 l capacity

Filtered water enters cool water tank A, then goes to hot water tank B and cold water tank C. Check valve is installed between the cool water tank and hot water tank, which prevents hot water from going back to the cool water tank. When the tanks are filled with water, hydraulic floating valve shuts off water supply to cool water tank.

4.3 WATER COOLING SYSTEM

Water cooling system contains the following elements: compressor, condenser and steamer. A freon-free refrigerant R134 circulates in the cooling system. In order to keep the temperature at the same low level thermal insulation is used in the cold water tank.

4.4 FLOW RESTRICTOR

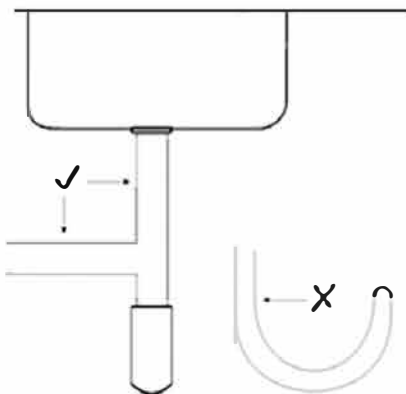

Drain saddle valve mounting positions

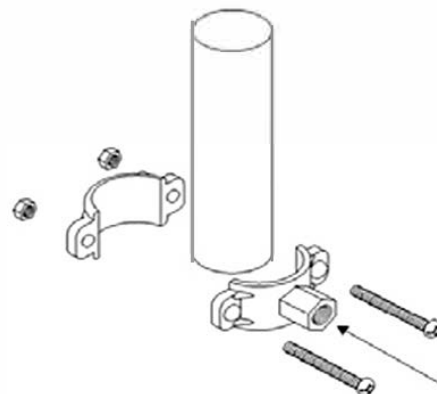

Drain saddle valve parts

A flow restrictor is located on the line before the drain saddle. It is used to regulate pressure and sewage volume after the purification process.

5. WATER DISTRIBUTOR CW-929 BASIC TECHNICAL PARAMETERS

Raw water pressure range		2,2 – 6,0 bar
Raw water temperature range		4 – 45 °C
Cooling system		Freon-free
Max inlet TDS		1500 ppm (*)
Max chlorine concentration level		2.0 ppm
Content of minerals in raw water		min. 121 mg/l
Raw water pH range		2 - 11
Minimum rejection (for new membrane)		90 – 95 %
Capacity		do 300 l/day
Cold water temperature range		4 -12 °C
Hot water temperature range		85-100 °C
Cold water tank		4 l
Hot water tank		2 l
Cool water tank		8 l
Power consumption – hot water		700 W
Power consumption – cold water		100 W
Voltage / frequency		~230 V /50 Hz
Dimensions	S x G x H	320x400x1040 mm
Net weight		19 kg

(*) - raw water hardness < 17 mg CaCO₃

- turbidity < 1NTU
- SDI (colloidal index) <5
- Fe < 0,01 mg/l
- Mn < 0,05 mg/l
- Si < 25 mg/l

6. INSTALLATION SCHEMES

6.1 WATER INSTALLATION SCHEME

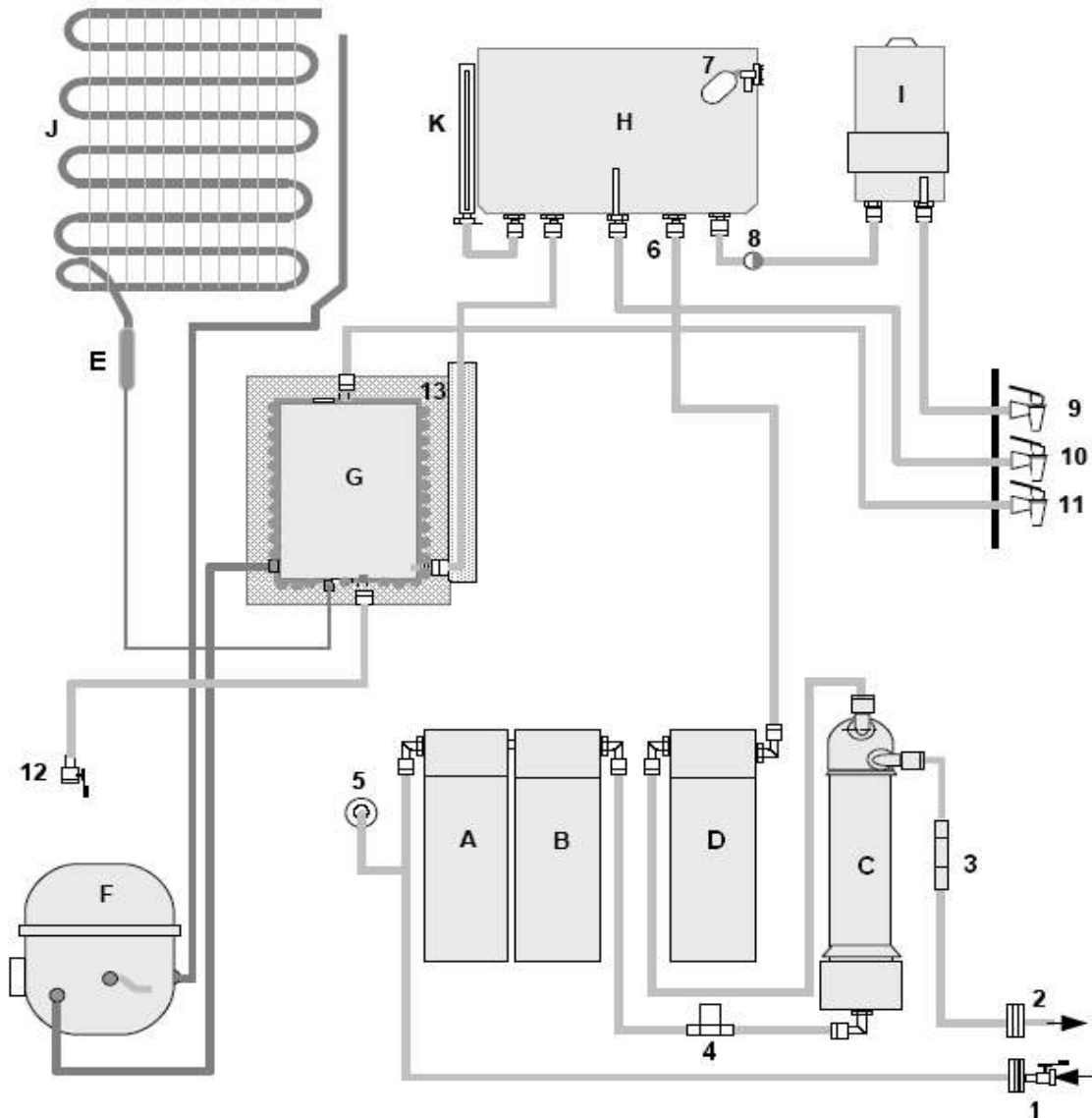

- A – Sediment cartridge (prefilter)
- B – Sediment-carbon cartridge (prefilters)
- C – Membrane in membrane housing
- D – Granular activated carbon cartridge (postfilter)
- E – Drier
- F – Cooling system compressor
- G – Cold water tank
- H – Cool water tank
- I – Hot water tank
- J – Cooling system condenser
- K – Water level indicator

- 1 – Water feeder (3/8" , 1/2" , 3/4")
- 2 – Drain saddle
- 3 – Flow restrictor (QC-type)
- 4 – Solenoid valve
- 5 – Low pressure valve
- 6 – Pure water inlet
- 7 – Hydraulic floating valve
- 8 – Check valve
- 9 – Hot water valve
- 10 – Cool water valve
- 11 – Cold water valve
- 12 – Water release valve
- 13 – Thermal insulation

6.2 ELECTRICAL INSTALLATION SCHEME.

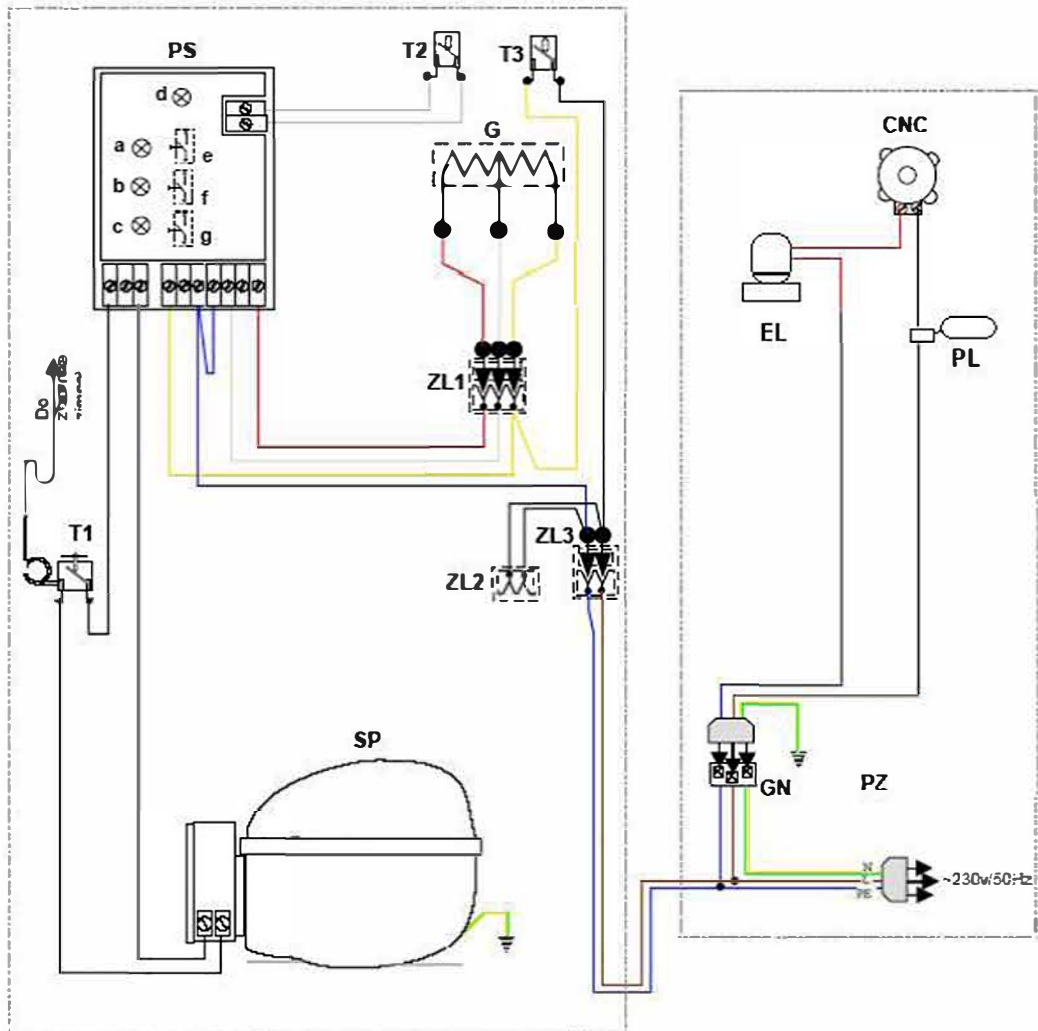

Electrical scheme

- EL Electrovalve
- CNC Low pressure switch
- PL Floating valve with a switch
- GN Power supply socket - Voltage ~230 V; 50Hz
- PZ Power supply cable with plug

WATER DISTRIBUTOR CW-929

- PS Control panel
 - a- LED POWER diode
 - b- LED KEEP WARM diode
 - c- LED HEATING diode
 - d- LED diode
 - e- microswitch COLD POWER
 - f- microswitch HOT POWER
 - g- microswitch REBOIL
- SP Compressor
- G Hot water tank heater
- T1 Cooling system thermostat
- T2 Hot water tank thermostat - 90°C
- T3 Hot water tank thermostat - 105°C
- ZL1 Three-way insert fitting
- ZL2 Two-way insert fitting
- ZL3 Two-way insert fitting

7. USEFUL INSTALLATION TIPS



In case of when Water Distributor contains QC-type connections (quick connections) it is sufficient enough to push in the installation tubes into every QC fitting.

7.1 Standard QC push-in fitting installation.



Push in hard the tube in the fitting. Locking clips prevent the tube from slipping out and the inner rubber gasket assures perfect sealing.

Pull the tube to check if it is well-fitted. It is advisable to check the system under pressure for possible leakage before you leave.

7.2 Disconnecting the QC push-in fittings.



Make sure that there is no pressure in the system. Push the locking clip to the front of the fitting. Take out the tube holding the locking clip. The fitting may be used again.

8. WATER DISTRIBUTOR INSTALLATION TO WATER MAINS



8.1 INSTALLATION AT COLD WATER INLET

8.1.1 METHOD 1: 3/4" water feeder – installation at faucet

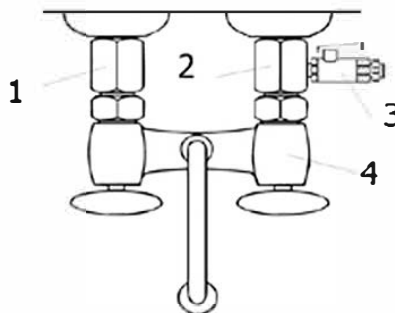

Water feeder faucet connection

(1 – hot water connector element 3/4", 2 – cold water connector element 3/4",
3 – ball valve, 4 – faucet)

1. Locate the hot and cold water valves under the kitchen sink and close them. Open the hot and cold water tap to release the remaining water. Make sure that water inlet is closed.

2. Unscrew the compression nuts and remove the faucet. Put the rubber gaskets and install connector elements, remembering that the element with a hole should be mounted on the main cold water inlet. Tighten firmly.
3. Screw in the ball valve into the water connector element.
4. Install the faucet elements to water feeder. Close the hot and cold water tap and the ball valve. Then open the hot and cold water inlet to check for possible leakages.
5. Use teflon tape to seal the threaded connections.
6. Connect the ball valve with the filter by the use of 1/4" elastic tube, which is included in the filter set.

8.1.2 METHOD 2: 3/8" or 1/2" water feeder – installation at water inlet

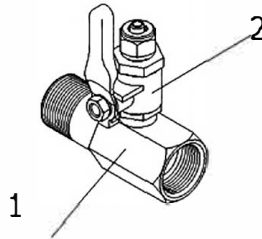

Water feeder connection set
(1 - connector element 3/8" or 1/2", 2 - ball valve)

1. **Step 2: Installing the dispensing faucet**
2. Locate the cold water valve under the kitchen sink (if water feeder is to be installed behind the valve) or main shut-off valve (if water feeder is to be installed before the valve, just like on the above scheme), and then turn off water inlet. Open the cold water tap in the faucet in order to release the remaining water.
3. Unscrew the nut on the installation tube or shut-off valve. Put on rubber gasket and mount the water feeder element. Tighten firmly.
Screw in the ball valve into the water feeder element.
4. Install the connection tube to water feeder element or mount the shut-off valve. Close the ball valve and then open the main shut-off valve or cold water inlet valve in order to check for possible leakages.
5. Use teflon tape to seal the threaded connections.
6. Connect the ball valve with the filter by the use of 1/4" elastic tube, which is included in the filter set.

8.2 INSTALLATION OF DRAIN SADDLE

1. Drain saddle fits the majority of standard Ø 50 mm sewage pipes. Drain saddle should be mounted above the siphon trap on the vertical or horizontal pipe under the sink drain.
2. Remove the nuts and bolts from the front half of the saddle, position and hold it in the desired location on the drain pipe above the siphon trap and water line and mark the spot for drilling with a Ø 4 mm drill bit or awl through the whole in the clamp. Do not mount the drain saddle near the garbage disposal, as this may cause the drain line to clog. You should carefully consider the route and available space for the 1/4" drain line tubing before you drill the 1/4" hole.

3. Drill a Ø 6 mm hole in the location marked in point 8.2.2 into the drain pipe and clean the surface of the pipe.
4. Remove the paper protection and round inner part from the foam gasket that is included in the set. Stick it to the drain pipe exactly in the place where the hole in gasket covers the hole in the pipe.
5. Align the drilled hole in the drain pipe with the front half of the drain saddle using a Ø 4 mm bit or a narrow screwdriver. Now locate the complementary piece of the drain saddle assembly clamp and join them together with the bolts. Tighten the two bolts evenly.
6. Connect 1/4" tubing to the drain saddle and the other free end to the flow restrictor valve.

8.3 PRESSURE CONTROL AND SYSTEM RINSING

1. Check all tubes so that there is a free passage.
2. Connect Water Distributor to power supply. **DO NOT** push the "HOT WATER" button until the main tank is filled with water.
3. Slowly open the cold water inlet valve. Once the pressure in the system increases, check for possible leakages.
4. Air will be escaping from the system and after about 5 minutes filtered water will start entering the main tank.

5. **FIRST TWO FULL TANKS MUST BE EMPTIED BEFORE YOU CAN DRINK THE FILTERED WATER.**



OPEN THE TANK DRAIN VALVE EVERY TIME TO EMPTY THE TANKS COMPLETELY.

6. **Only after you have emptied the tank for the second time can you drink the filtered water!**

9. WATER DISTRIBUTOR OPERATION CONDITIONS

9.1 PRECAUTIONS

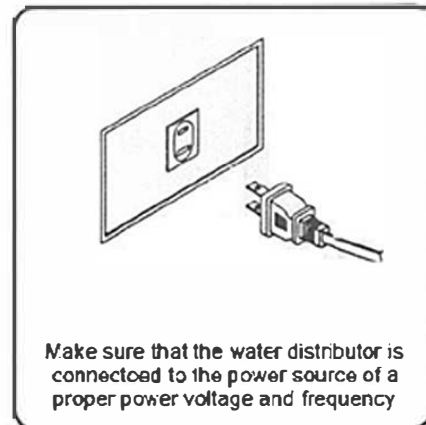
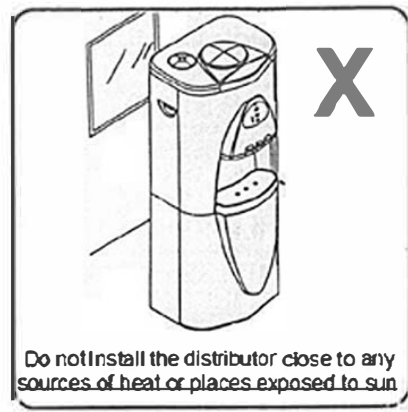
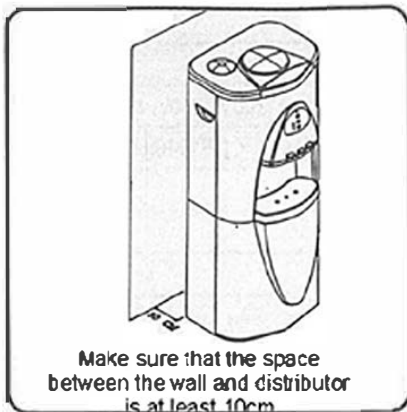

9.2 HOW TO GET WATER OF A REQUIRED TEMPERATURE

1. After you connect Water Distributor to power supply press “HOT POWER” button. “POWER ON” light will be on.

When water is boiled to 100 degrees C, the light on the control panel will change from “HEATING” to “KEEP WARM”

Water Distributor fills in the main water tank and keeps it warm even at different intervals, without the necessity to press “REBOIL” button. Thanks to this function a constant access of hot water is assured.



2. Press “REBOIL” to heat water. At this moment the light will change from “KEEP WARM” to „HEATING”.

3. In order to cool water first press the cold water button lever and then “COLD POWER” button.

CAUTION: If it is not necessary, do not press “COLD POWER” button. You can do it again after 3 minutes 3 min. (in order to protect the compressor).



Cold water temperature is set within the range 4-12 degrees C.

You can regulate the temperature by the use of a controller mounted at the back side of Water Distributor. The higher the value on the scale the lower the temperature.



10. WATER DISTRIBUTOR SERVICE AND MAINTENANCE

10.1 WATER DISTRIBUTOR CLEANING

1. Make sure Water Distributor is unplugged before you start cleaning.
2. Remove the top cover, cool water tank cover and hot water tank cover.
3. By the use of cold, cool and hot water button levers release the remaining water.

4. In order to empty the cold water tank remove the drain plug from the water tank, which is located at the back side of the Water Distributor.

5. Clean the hot and cool water tanks ONLY by the use of disinfecting substances admitted for food industry by appropriate authorities.

CAUTION: DO NOT TILT THE WATER DISTRIBUTOR TO THE SIDES DURING CLEANING. IT MAY CAUSE SEVERE SYSTEM DAMAGES BY FLOODING IT WITH WATER. AFTER YOU HAVE CLEANED OR INSTALLED THE SYSTEM, WAIT 10 MINUTES BEFORE YOU PRESS “COLD WATER” BUTTON.

10.2 PREFILTERS EXCHANGE

CAUTION: THE PRODUCER DOES NOT TAKE RESPONSIBILITY FOR INSTALLING CARTRIDGES, MEMBRANES AND OTHER REVERSE OSMOSIS EQUIPMENT ELEMENTS DIFFERENT THAN THOSE PROVIDED IN THE SET. THE PRODUCER IS NOT LIABLE FOR ANY DAMAGES CAUSED TO THE SYSTEMS DUE TO IMPROPER INSTALLATION OR USAGE OF WATER TREATMENT ELEMENTS.

In order to exchange the prefilters, follow the instructions given below:

1. Cut off water supply by turning the ball valve located on the water supply to the close position.
2. Unplug the Water Distributor.
3. Leave the system for 3-5 minutes in order to lower the pressure to the minimum.
4. Unscrew the prefilters to the left (counterclockwise). Do it carefully, as the cartridges are filled with water.
5. Install new prefilters on prefilter's head by turning them clockwise. Tighten them firmly. DO NOT use any wrenches to change prefilters.

CAUTION: Replacement period depends on raw water quality. It is advisable to periodically control prefilters' condition in between the required period of filter replacement and record the results. These results will allow to prepare an individual service programme adjusted to particular raw water conditions.

10.3 MEMBRANE EXCHANGE

Insert new membrane into housing in this direction

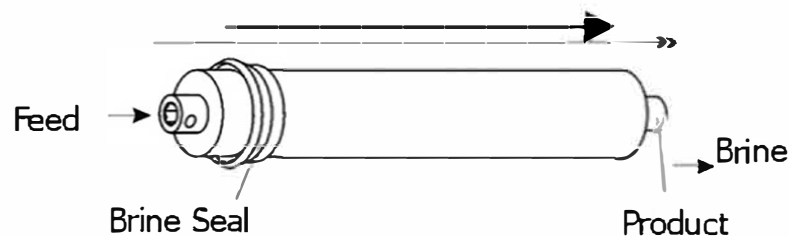

Membrane Scheme

Follow the instructions below in order to exchange membrane.

1. Cut off water supply by turning the ball valve located on the water supply to close position.
2. Remove 1/4" tube from the head side of the membrane housing according to the instructions provided on page 11.
3. Unscrew the head of the membrane housing turning it counterclockwise. Make sure that rubber o-rings remained on the thread of the housing in their original position.
4. Using a pair of pliers take the plastic end of the membrane core and take the membrane out. This activity may entail slight turnings to the left and right, because the membrane is well fitted inside the housing.



UNPACK THE MEMBRANE FROM FOIL BEFORE INSTALLATION



PUT VASELINE ON RUBBER O-RINGS BEFORE INSTALLING THE MEMBRANE

⚠ **PUT THE MEMBRANE INSIDE THE HOUSING ALWAYS IN THE DIRECTION POINTED ON THE ABOVE SCHEME**

10.4 POSTFILTERS EXCHANGE

Follow the instruction given below in order to exchange the postfilters:

1. Cut off water supply by turning the ball valve located on the water supply to close position
2. Leave the system for 3-5 minutes in order to lower the pressure to the minimum
3. Unscrew the postfilters to the left (counterclockwise). Do it carefully, as the cartridges are filled with water.
4. Install new posfilters on postfilter head by turning them clockwise. Tighten them firmly. DO NOT use any wrenches to change postfilters.

1. Prefilters exchange: every 3 to 6 months
2. Posfilters exchange: every 6 months
3. Membrane exchange: every 2 to 5 yers

11. TROUBLESHOOTING

PROBLEM	CAUSE	SOLUTION
LACK OF POWER SUPPLY	Lack of power supply in the main electrical system	Check the connection to electrical system and all cables.
	The system switches off automatically when water level is lower than the required minimum.	Fill in the main water tank with water and press "HOT POWER" and/or "COLD POWER" buttons to restart the system.
	The system does not start after a short period of power cut-off, although it was not unplugged.	Press "HOT POWER" and/or "COLD POWER" buttons to restart the system.
WATER DOES NOT FLOW FROM THE MAIN TANK TO COLD AND HOT WATER TANKS	The connections between the tanks may have become clogged.	Remove the top cover, empty the tanks and clean the connections between the tanks.
WATER DISTRIBUTOR HEATS WITHOUT STOPPING	"REBOIL" button has been pressed several times.	Press "REBOIL" button once and observe system's reactions. If the situation repeats, most probably temperature controller is damaged. If so, then the system will need professional service.
THE HEATING CYCLE IS MORE FREQUENT THAN USUAL	There is too little water in hot water tank.	Refill the main tank with water.

PROBLEM	CAUSE	SOLUTION
COLD WATER IS TOO WARM	Water Distributor is installed too close to wall.	Move the Distributor to reach minimum 10 cm space from the wall.
	The surface of the condenser is covered with dust.	Clean the condenser every 3 months.
	Water Distributor is installed in a stuffy room.	Place the system in an airy room.
	There is not enough fluid in the compressor	Contact the service centre